

Bimetal Thermometer

Model TI.54, All Stainless Steel Construction

Datasheet TI.54

Applications

- Suitable for fluid medium which does not corrode 304 stainless steel

Special features

- Industrial design
- Lower (bottom) connection without external reset
- All stainless steel construction

Standard version

Size

5" (127mm)

Accuracy

± 1.0% full scale value (ASME B40.3)

Ranges

-100 °F to 1000 °F (and equivalent Celsius)

Working Range

Steady: full scale value

Short time: 110% of full scale value

Under/Over Range Protection

Temporary over or under range tolerance of 50% of scale up to 500 °F. (260 °C). For ranges above 500 °F, maximum over range is 800 °F; continuous. 1000 °F intermittent.

Connection

Material: 304 stainless steel

Lower mount (LM), 1/2" NPT

Stem

Material: 304 stainless steel

Diameter: 1/4" (6.35 mm)

Length: 2½" to 24" (63.5 mm to 609.6 mm)

Measuring Element

Bi-metal helix

Dial

White aluminum, dished, with black markings



Thermometer TI.54

Case

Material: 304 stainless steel

Hermetically sealed

Pointer

Black aluminum

Standard Scales

Single: Fahrenheit or Celsius

Dual: Fahrenheit (outer) and Celsius (inner)

Window Gasket

Neoprene

Silicone (-100 °F and over 550 °F)

Window

Flat instrument glass

Weight

24 oz. (5" dial)

Add 1 oz for every 2" of stem length

Dampening

Inert gel to minimize pointer oscillation

Movement

Viscous inert gel to enhance pointer operation

Warranty

Limited one year warranty as stated in WIKA's Terms & Conditions of Sale

Optional Extras

- Thermowells
- Special scales and dial markings
- Acrylic and safety glass windows
- Calibration certification traceable to NIST

STANDARD RANGES		
Fahrenheit	Dual Scale F & C	Celsius
Single Scale	F Outer, C Inner	Single Scale
-100/150 F	-100/150 F & -70/70 C	-50/50 C
-40/120 F	40/120 F & -40/50 C	-20/120 C
0/140 F	0/140 F & -20/60 C	0/50 C ¹
0/200 F	0/200 F & -15/90 C	0/100 C
0/250 F	0/250 F & -20/120 C	0/150 C
20/240 F	20/240 F & -5/115 C	0/200 C
25/125 F ¹	25/125 F & -5/50 C ¹	0/250 C
50/300 F	50/300 F & 10/150 C	0/300 C
50/400 F	50/400 F & 10/200 C	0/450 C ²
50/550 F	50/500 F & 10/260 C	100/550 C ²
150/750 F	150/750 F & 65/400 C	
200/1000 F ²	200/1000 F & 100/540 C ²	

¹Minimum stem length 4"

²Not recommended for continuous service over 800°F (425°C)

Dimensions

Standard versions

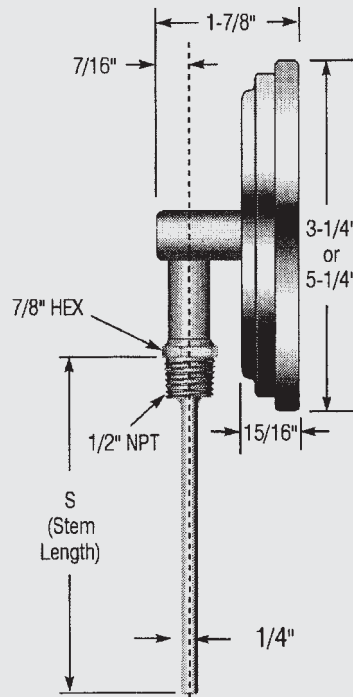

STEM LENGTH
2½" (63.5 mm)
4" (101.6 mm)
6" (152.4 mm)
9" (228.6 mm)
12" (304.8 mm)
15" (381.0 mm)
18" (457.2 mm)
24" (609.6 mm)

Bottom Connected (Types 34 & 54)

WIKA TYPE	DIAL SIZE	A	B	S (Stem Length)
54	5" (127 mm)	5-1/4" (133.4 mm)	1-7/8" (47.6 mm)	As Specified

Note: Thermowells for temperature instruments are recommended for all process systems where pressure, velocity, or viscous, abrasive and corrosive materials are present individually or in combination. A properly selected thermowell protects the temperature instrument from possible damage resulting from these process variables. Furthermore, a thermowell permits removal of the temperature instrument for replacement, repair or testing without effecting the process media or the system.

Ordering information

State computer part number (if available) /type number/size/range/connection size and locations/options required. WIKA reserves the right to make changes without prior notice.



WIKA Instrument Corporation

1000 Wiegand Boulevard
 Lawrenceville, GA 30043
 1-888-WIKA-USA /770-513-8200 (in GA)
 Fax 770-338-5118
 info@wika.com www.wika.com