



# Diaphragm-Type Diaphragm Seal

## Threaded Sanitary Diaphragm Seal

Type L990.18

### Chemical Seals

#### Application

Food & Beverage and Pharmaceutical industry diaphragm seal to combine with Bourdon tube pressure gauges or transmitters. Intended for hygienic pressure media.

#### Design

External, flush diaphragm and female or male hygienic – type connection, which requires hydraulic fluid to transmit pressure to instrument.

#### Process Connection

DN25 to DN80 per DIN11851

#### Instrument Connection

Capillary, 1/4" or 1/2" NPT-female

#### Suitable Pressure Ranges

15 PSI to 600PSI

#### Available Options (connections, materials, etc.)

See Selection Guide (over)

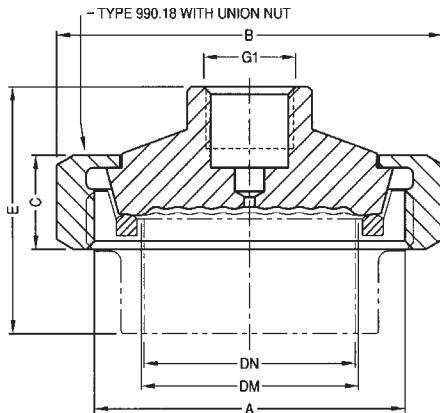

DN=NOMINAL PIPE SIZE  
DM=EFFEKTIVE DIAPHRAGM DIAMETER  
ALL DIMENSIONS IN INCHES UNLESS OTHERWISE NOTED

DN	MWP	A	B	C	DM	E	G1	WEIGHT
[mm]	psi	[mm]						lbs
25	600	Rd52x1/6	2.48	0.83	1.0	2.36	1/4NPT OR 1/2NPT FEMALE	1.3
32	600	Rd58x1/6	2.76	0.83	1.3	2.72		1.6
40	600	Rd65x1/6	3.07	0.83	1.6	2.17		2.5
50	360	Rd78x1/6	3.62	0.87	2.1	2.32		2.8

DWG.#2211971-5

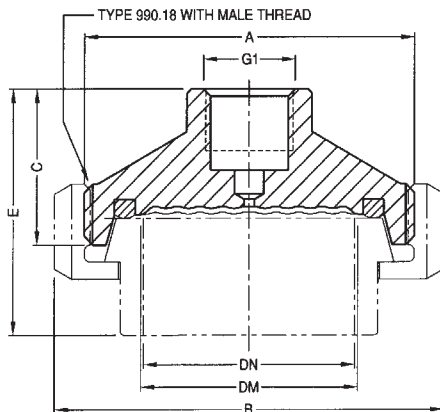

DN=NOMINAL PIPE SIZE  
DM=EFFEKTIVE DIAPHRAGM DIAMETER  
ALL DIMENSIONS IN INCHES UNLESS OTHERWISE NOTED

DN	MWP	A	B	C	DM	E	G1	WEIGHT
[mm]	psi	[mm]						lbs
40	600	Rd65x1/6	3.07	1.42	1.6	2.17	1/4NPT OR 1/2NPT FEMALE	2.8
50	360	Rd78x1/6	3.62	1.42	2.1	2.24		3.0

DWG.#2211971-5

To determine the effects of temperature and response time in a specific application, contact the factory for an **Application Questionnaire**. The information provided will allow WIKA Technical Support to accurately model your application parameters using state-of-the-art computer simulation techniques.

**ACSL990.18**  
(ACS 99.08T)

# Selection Guide - L990.18

L990.18,1/4X25,SS,SS,BU,U

## Options (See note 4)

U = Upper housing with union nut

## Sealing Ring Material

BU = Buna "N"

TF = Teflon®

NA = Without o-ring

## Diaphragm Material (See note 3)

SS = 316 stainless steel

MO = Monel® 400

HC = Hastelloy® C-276

HB = Hastelloy® B-2

NI = Nickel 200

TI = Titanium, grade 2

## Upper Housing Material (See notes 2 & 3)

SS = 316 stainless steel

MO = Monel® 400

HC = Hastelloy® C-276

HB = Hastelloy® B-2

NI = Nickel 200

TI = Titanium, grade 2

## Process Connection

25 = DN 25

32 = DN 32

40 = DN 40

50 = DN 50 (See note 1)

80 = DN 80

## Instrument Connection

1/4 = 1/4" NPT female

1/2 = 1/2" NPT female

CPL = Capillary connection (To weld capillary directly to seal)

## Notes

1. Maximum working pressure is 400 PSI.
2. Upper housing is a process wetted component.
3. Upper housing and diaphragm material must be the same.
4. Union nut is a process wetted component.

*Items in **bold** are available from stock (subject to prior sales). For optional items, consult factory for current lead-time.*

## Diaphragm Seal Design (MWP = 600 PSI)

L990.18 = Sanitary Seal with Threaded Connection

Options not listed may be available, please consult factory.  
Fill Fluid & Mounting options: Please reference data sheet ACS 99.MO.

THE MEASURE OF  
**Total Performance™**

## Ordering Information:

State computer part number (if available) / type number / size / range / connection size and location / options required.

Specifications given in this price list represent the state of engineering at the time of printing. Modifications may take place and the specified materials may change without prior notice

05/01



**WIKAL Instrument Corporation**

1000 Wiegand Boulevard

Lawrenceville, Georgia 30043-5868

Tel: 770-513-8200 Fax: 770-338-5118

<http://www.wika.com> e-mail: [chemseal@wika.com](mailto:chemseal@wika.com)