



Capsule-Type Diaphragm Seal

Threaded Running Nut Diaphragm Seal

Type L970.11

Diaphragm Seals

Application

Protects pressure instrument (Bourdon tube pressure gauge or transmitter) intended for high pressure. Suitable for corrosive, contaminated, hot or highly viscous and low to medium velocity media.

Design

Oval capsule probe diaphragm with internal support, threaded process connection; requires hydraulic fluid to transmit pressure to instrument.

Process Connection

1/2" to 1" NPT male, running nut

Instrument Connection

Capillary, 1/4" or 1/2" NPT female

Suitable Pressure Ranges

100 PSI to 20,000 PSI

Available Options (connections, materials, etc.)

See Selection Guide (over)

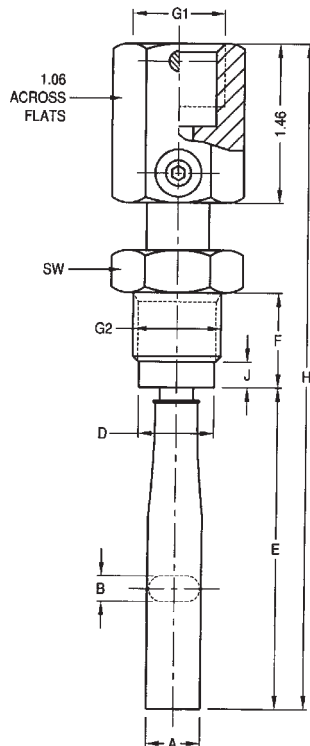

SW: WRENCH SIZE
 G1: INSTRUMENT CONNECTION
 G2: PROCESS CONNECTION
 ALL DIMENSIONS IN INCHES UNLESS OTHERWISE NOTED

G1	G2	A	B	C	E	F	H	J	SW	WEIGHT
										lbs
1/2"NPT	G1/2B	0.51	0.24	0.71	2.95	0.89	6.10	0.24	1.06	0.66
	G3/4B	0.71	0.28	0.94	3.94	0.94	7.09	0.24	1.26	0.88

DWG.#2212129-5

To determine the effects of temperature and response time in a specific application, contact the factory for an **Application Questionnaire**. The information provided will allow WIKA Technical Support to accurately model your application parameters using state-of-the-art computer simulation techniques.

ACSL970.11
 (ACS 97.01)

Selection Guide - Type L970.11

Type L970.11, 1/4X1/2M, SS, SS, 3.0

Probe Length
3.0 = 3"
4.0 = 4"

Diaphragm Material
SS = 316 stainless steel

Upper Housing Material
SS = 316 stainless steel

Process Connection

1/2M = 1/2" NPT male (Probe length 3")
3/4M = 3/4" NPT male (Probe length 4")
1.0M = 1" NPT male (Probe length 4")

Instrument Connection

1/4 = 1/4" NPT female
1/2 = 1/2" NPT female
CPL = Capillary connection (To weld capillary directly to seal)

Diaphragm Seal Design (MWP = 20,000 PSI)

Type L970.11 = Capsule Seal Design, with male running nut (See Note 1)

Notes

1. Contact factory for available configurations.

Options not listed may be available, please consult factory.
Fill Fluid & Mounting options: Please reference data sheet ACS 99.MO.

THE MEASURE OF
Total Performance™

Ordering Information:

State computer part number (if available) / type number / size / range / connection size and location / options required.

Specifications given in this price list represent the state of engineering at the time of printing.
Modifications may take place and the specified materials may change without prior notice

05/01



WIKA Instrument Corporation

1000 Wiegand Boulevard

Lawrenceville, Georgia 30043-5868

Tel: 770-513-8200 Fax: 770-338-5118

<http://www.wika.com> e-mail: chemseal@wika.com