

- 4½" & 6" Case Sizes
- Many case styles to choose from
- Panel mount, stem mount and wall mount
- Bronze systems standard⁽¹⁾
- Solid-front case style
- 3-15 psi input with optional 3-27 psi input

Ashcroft® receiver gauges are used in conjunction with pneumatic transmitters to indicate pressure, temperature, flow or other process parameters that can be transmitted by proportional variations in air pressure.



Type 1017 Case Style

(1) Stainless Steel (S); Monel (P) optional

SPECIFICATIONS

Gauge Type Number	Dial Sizes	Case/ring Material	System Assembly	Pressure Range-psi	Pointer	Movement	NPT Conn.	Accuracy
1017A-XPR	4½", 6"	Aluminum	Phosphor Bronze Bourdon tube, brass socket, silver brazed	3/15 and 3/27	Black, Adjustable	Rotary geared, stainless steel pinion and segment shaft	1/4	ASME B40.1 Grade 1A (±1% of span)

Gauge Type Number	Dial Size (Inches)	Connection Location	Mounting	Method
1017A-XPR	4½", 6"	Lower/Back	Stem, Surface, Flush	-

STANDARD RANGES⁽¹⁾

0-10 sq rt/0-100 linear dual-scale
0-10 square root
0-100 linear

(1) Other ranges on request.

TO ORDER THESE RECEIVER GAUGES:

Select: _____ 45 _____ 1017 _____ A _____ 02 _____ L _____ XPR _____ 3-15 psi

- Dial size _____
- Case type _____
- Tube and socket material _____
- Connection size, ¼ (02), ½ (04) _____
- Connection location, (L-Lower), (B-Back) _____
- Optional features (XPR always appears in code for receiver gauge) _____
- Range of transmitted signal (also specify the scale to be shown on the dial face) _____

Case Type 1017

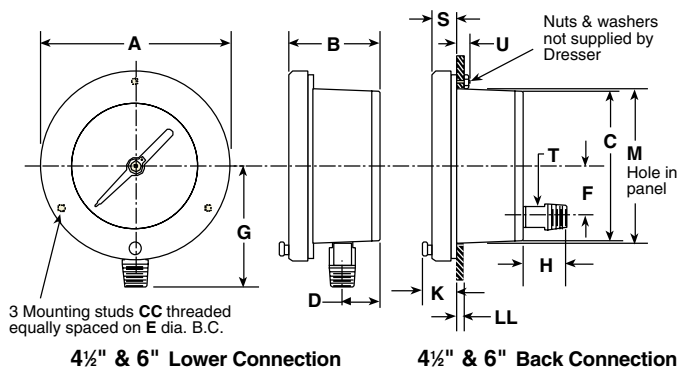

Dial Size Inches	A	B	C	D	E	F	G	H	Weight (lbs)
4 1/2	6 3/32 (148)				5 3/8 (137)		3 15/16 (100)		2 1/2
6	7 9/16 (192)	2 7/8 (73)	4 3/4 (121)	1 1/16 (27)	7 (178)	1 5/8 (41)	4 1/2 (114)	1 3/8 (35)	3

Dial Size Inches	K	M	P	S	T	U	CC	LL	Weight (lbs)
4 1/2		4 7/8 (124)					#10-24		2 1/2
6	1 1/16 (27)	6 1/2 (165)	2 1/8 (54)	5/8 (16)	5/8 (16)	3/4 (19)	1/4-20	1/8-1/2 (3)(13)	3