

- **Standard dials offer four refrigerant scales (R12, R22, R502, 134A)**
- **FlutterGuard™ eliminates pointer flutter**
- **Patented PowerFlex™ movement with polyester segment**

Ashcroft® Types 1001T, XOR 1007P, XOR and 1005, XOR are designed to meet the unique requirements of the HVAC, automotive and refrigeration industries.

Ashcroft Type 1001T, XOR gauges are designed for refrigerant recovery and recycling units. All gauges for this service are tested for leaks as

small as  $2.8 \times 10^{-4}$  cc per second to ensure superior integrity. Optional connections eliminate potential leaks at threaded joints and also eliminate customer cost for extra fittings.

Ashcroft Type 1007P, XOR gauges are designed for installation on refrigeration manifolds used in testing automotive, industrial and residential air-conditioning units. The ABS case offers rugged durability and corrosion resistance.

Ashcroft Type 1005, XOR gauges are 80mm in diameter for better dial visibility. These gauges have color-coded steel cases and internally threaded polycarbonate windows.



1001T, XOR gauge shown

FlutterGuard, a standard feature in these gauges, eliminates pointer flutter and extends gauge life.

GAUGE SPECIFICATIONS	TYPE 1001T, XOR	TYPE 1007P, XOR	TYPE 1005, XOR
<b>Size:</b>	2½", 3½"	2½"	80mm
<b>Accuracy:</b>	1% at zero, 2% three fourths of scale, 5% last fourth of scale	1% at zero, 2% three fourths of scale, 5% last fourth of scale	1% at zero, 2% three fourths of scale, 5% last fourth of scale
<b>Case:</b>	Black steel with studs and U-clamp for panel mounting	Red ABS - high pressure Blue ABS - low pressure	Steel, painted blue (low pressure) Steel, painted red (high pressure)
<b>Ring:</b>	None	None	None
<b>Window:</b>	¼ turn polycarbonate, threaded	Polycarbonate, threaded	Internally threaded polycarbonate
<b>Dial:</b>	Refrigerant scales R12, R22, R502, R134A, 410A	Refrigerant scales R12, R22, R502, R134A, 410A	Refrigerant scales R12, R22, R502, R134A, 410A
<b>Pointer:</b>	Black, aluminum	Black, aluminum	Black, aluminum
<b>Bourdon tube:</b>	Bronze	Bronze	Bronze
<b>Movement:</b>	Patented PowerFlex with polyester segment and FlutterGuard; slotted span screw for minor span adjustments	Patented PowerFlex with polyester segment and FlutterGuard; slotted span screw for minor span adjustments	Patented PowerFlex with polyester segment and FlutterGuard; slotted span screw for minor span adjustments
<b>Socket:</b>	Brass	Brass	Brass
<b>Restrictor:</b>	0.013" orifice throttle plug	0.020" orifice throttle plug	0.020" orifice throttle plug
<b>Connection:</b>	½ NPT back, ¼ NPT back	½ NPT lower	½ NPT lower
<b>Ranges:</b>	30 in.Hg vac./0/120 psi retard to 250 psi; 0-500 psi; 30 in.Hg vac./0/350 psi retard to 500 psi; 0-800 psi	30 in.Hg vac./0/120 psi retard to 250 psi; 0-500 psi; 30 in.Hg vac./0/350 psi retard to 500 psi; 0-800 psi	30 in.Hg vac./0/120 psi retard to 250 psi; 0-500 psi; 30 in.Hg vac./0/350 psi retard to 500 psi; 0-800 psi
<b>Operating temp.:</b>	-40°F to 150°F	-40°F to 150°F	-40°F to 150°F
<b>Options:</b>	Nonstandard ranges Alternate refrigerant ranges SAE Flare, solder bib and ferrule connections, Customized dials	Nonstandard ranges Alternate refrigerant ranges Case color Customized dials	Nonstandard ranges Alternate refrigerant ranges Retard to 350 psi, Customized dials Bulk packaging, Black case

### TO ORDER THIS TYPE 1001T, XOR / 1007P, XOR/ 1005, XOR GAUGE:

Select:

1. Dial Size: 2½"	25	W	1007	P	H	01L	X(OR)	120#/Vac
2. Patented PowerFlex™ Movement								
3. Case Type Number: 1007								
4. Case material: ABS								
5. Socket Material: Brass								
6. Connection Size/Location: ½ NPT lower								
7. Refrigeration Application								
8. Range: 30" Hg vac./0/120 psi retard to 250 psi								

## TYPE 1001THT U-Clamp (UC) TYPE 1001THT Front Flange (FF)

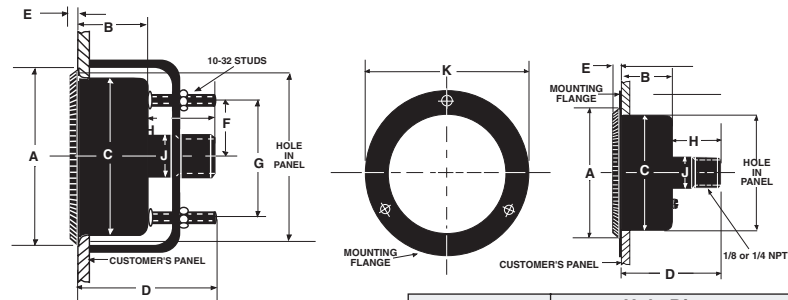

Panel Cut-out:	Hole Diameter		
	Min.	Max.	Max. Panel Thickness
2½" Gauge:	2 <sup>3</sup> / <sub>64</sub> "	2¼"	7/16"
3½" Gauge:	3 <sup>5</sup> / <sub>8</sub> "	3 <sup>13</sup> / <sub>16</sub> "	7/16"

Case Type 1001T (UC)												
INCHES (MM)	A	B	C	D	E	F	G	H	J	K	L	Conn. NPT
2½"	2.87 (73)	0.97 (25)	2.57 (65)	1.97 (50)	0.16 (4)	1.00 (25)	2.00 (51)	0.88 (22)	9/16 sq. (14)	-	-	1/8 or 1/4
3½"	3.96 (101)	1.00 (25)	3.61 (92)	1.72 (44)	0.20 (5)	1.53 (39)	3.06 (78)	0.88 (22)	9/16 sq. (14)	-	-	1/8 or 1/4
Case Type 1001T (FF)												
2½"	2.87 (73)	0.97 (25)	2.59 (66)	-	0.17 (4)	-	-	0.86 (22)	9/16 sq. (14)	3.69 (94)	3.31 (84)	1/8 or 1/4